



Inmarsat FleetBroadband Rates effective 1st January 2017.

Changes summary.

Introducing new FleetBroadband and Fleet One plans.

- Inmarsat is introducing more flexible short-term plans to support seasonal customers: «FBB 75MB short term», «FBB 250MB short term», «FBB 1GB short term», «FBB 4GB short term» и «FBB 8GB short term» with minimum contract duration 3 months.

Subscription Suspension.

- The subscription suspension fee will be introduced since 1st of January 2017.
- There is an option to suspend the subscription (Subscription Suspension) for a number of the FleetBroadband rate plans. This functionality will apply to the rate plans as detailed in Tables below.
- Effective 01 January, 2017 the subscription suspension fee will be **375,00 usd**.

Monthly suspension subscription option usage conditions are below:

1.1

- A) Monthly suspension subscription option can be activated starting at 1st date of the calendar month
- B) Maximum 90 days per year
- C) During the Minimum Duration period the 90 days suspension could be taken as follows:
 - one Subscription Suspension period of 90 days,
 - three periods of 30 days,

When a Subscription Suspension period occurs during the Minimum Duration, the period of the Subscription Suspension will not count towards the Minimum Duration period.

1.2. During a Subscription Suspension period

- Any allowances are removed during a Subscription Suspension period
- Any usage during a Subscription Suspension period will be charged at the appropriate out of bundle rates for that rate plan.
- During a Subscription Suspension period, it is not possible for a SIM to be upgraded, downgraded, suspended or deactivated

1.3 Dual SIM Plan

Subscription Suspension is applied at a per vessel level and therefore applies to both SIMs.

Voice Allowance Plans

In addition to the data allowance plans, data and voice allowance plans are available.

There will be a choice of voice plans as follows:

- a. \$442,50 for 1,400 voice minutes
- b. \$619,50 for 2,190 voice minutes
- c. \$796,50 for 3,200 voice minutes

Annual options for Voice allowance plans are based on multiples of the options above.

The allowance minutes include calls to fixed line and cellular destinations only. For the avoidance of doubt on-net calls are not included within the allowance.

The minimum duration period of the voice allowance plan will be the same as the underlying data plan, e.g. 12 months for the 250MB plan. To access one of these plans, SIMs will need to be upgraded to the new plan and a new minimum duration period will commence. Data allowances will be unaffected.



1. Inmarsat FleetBroadband rate plans.

FleetBroadband rate plans effective 01.01.2017 (USD)

Service	Unit	FBB.COM	FBB 75MB	FBB 250MB	FBB 1GB	FBB 4GB	FBB 8GB	FBB 20GB	FBB 40GB
Minimum duration of the contract	month	1	12	12	12	24	24	24	24
Annual payment option	service	no	yes	yes	yes	yes	yes	yes	yes
Dual SIM option	service	no	yes	yes	yes	yes	yes	no	no
Activation	service	0,00	0,00	0,00	0,00	0,00	0,00	0,00	0,00
Subscription fee	month	\$300,00	\$550,85	\$990,00	\$1271,19	\$1584,75	\$2110,17	\$2793,00	\$3724,00
Subscription suspension	service	-	375,00	375,00	375,00	375,00	375,00	375,00	375,00
<i>Standard IP</i>									
Monthly inclusive MB allowance	Megabyte	25	75	250	1024	4096	8192	20480	40960
Standard IP out of allowance	Megabyte	\$18,65	\$11,25	\$5,85	\$1,95	\$0,59	\$0,39	\$0,20	\$0,09
<i>Telephony</i>									
Voice to Fixed	minute	\$0,49	\$0,45	\$0,38	\$0,32	\$0,28	\$0,28	\$0,28	\$0,28
Voice to Cellular	minute	\$0,69	\$0,62	\$0,53	\$0,46	\$0,39	\$0,39	\$0,39	\$0,39
Voice to voicemail	minute	\$0,49	\$0,45	\$0,38	\$0,32	\$0,28	\$0,28	\$0,28	\$0,28
Inmarsat-GSPS/FBB/SBB/BGAN	minute	\$0,49	\$0,45	\$0,38	\$0,32	\$0,28	\$0,28	\$0,28	\$0,28
<i>SMS</i>									
SMS-сообщение / SMS	event	\$0,30	\$0,26	\$0,24	\$0,17	\$0,11	\$0,11	\$0,11	\$0,11
Inmarsat FleetBroadband short term plans effective 01.01.2017 (USD)									
Service	Unit	FBB 75MB SHORT TERM	FBB 250MB SHORT TERM	FBB 1GB SHORT TERM	FBB 4GB SHORT TERM	FBB 8GB SHORT TERM			
Minimum duration of the contract	month	3	3	3	3	3			
Dual SIM option	service	yes	yes	yes	yes	yes			
Activation	service	0,00	0,00	0,00	0,00	0,00			
Subscription fee	month	\$780,00	\$1296,75	\$1620,00	\$2240,00	\$3045,00			
Subscription suspension	service	\$375,00	\$375,00	\$375,00	\$375,00	\$375,00			
<i>Standard IP</i>									
Monthly inclusive MB allowance	Megabyte	75	250	1024	4096	8192			
Standard IP out of allowance	Megabyte	\$13,81	\$7,43	\$2,48	\$0,74	\$0,50			
<i>Telephony</i>									
Voice to Fixed	minute	\$0,62	\$0,53	\$0,45	\$0,40	\$0,40			
Voice to Cellular	minute	\$0,87	\$0,74	\$0,64	\$0,55	\$0,55			
Voice to voicemail	minute	\$0,62	\$0,53	\$0,45	\$0,40	\$0,40			
Inmarsat-GSPS/FBB/SBB/BGAN	minute	\$0,62	\$0,53	\$0,45	\$0,40	\$0,40			
<i>SMS</i>									
SMS	event	\$0,32	\$0,30	\$0,21	\$0,15	\$0,15			



2. Inmarsat FleetBroadband circuit switched voice, ISDN calls to other MSS services and Streaming data rates.

For all Inmarsat FleetBroadband rate plans circuit switched voice, ISDN calls to other MSS services and Streaming data, the charges are as follows:			(USD)
<i>Telephony</i>			
Inmarsat-B	minute		\$2,04
Inmarsat-M	minute		\$1,74
Inmarsat-GAN/Fleet/Swift/MiniM	minute		\$1,50
Inmarsat-Aero	minute		\$2,94
Iridium	minute		\$6,60
Globalstar	minute		\$4,80
Thuraya	minute		\$3,00
Other MSS carriers	minute		\$4,14
<i>Fax, ISDN, including ISDN data, ISDN fax and 3.1Khz audio</i>			
Voice to Fixed	minute		\$4,90
Voice to Cellular	minute		\$4,90
Inmarsat-FBB/SBB/BGAN/GSPS	minute		\$4,90
Inmarsat-GAN/Fleet/Swift/MiniM/B/M/Aero	minute		\$11,20
Other MSS carriers	minute		\$11,20
<i>Streaming IP</i>			
8Kbps	minute		\$0,36
16Kbps	minute		\$0,72
24Kbps	minute		\$1,08
32Kbps	minute		\$3,00
64Kbps	minute		\$4,08
128Kbps	minute		\$12,00
256Kbps	minute		\$24,00
<i>Optional services</i>			
Public static IP address	month		\$51,33
WEB compression	Month		\$85,00
Multivoice activation	Service		\$70,00
(Firewall) Firewall management	Service		Free of charge
Cost monitoring	Service		Free of charge
Web portal access	Service		Free of charge
Marsatmail account allocation	service		Free of charge
IP traffic control on board	month		\$30,00

3. Voice Allowance Plans

USD

Service	Unit	1400 voice minutes	2190 voice minutes	3200 voice minutes
Subscription fee	month	\$442,50	\$619,50	\$796,50
Implied Charge per minute (Fixed and Cellular)	minute	\$0,33	\$0,29	\$0,26



Additional Fixed Voice Usage Charges per Minute	minute	\$0,33	\$0,29	\$0,26
Additional Cellular Voice Usage Charges per Minute	minute	\$0,42	\$0,38	\$0,35
Minimum contract duration	month	12/24		

4. Terms and conditions:

4.1. All rates are in USD. VAT is not included.

4.2. A subscription fee will be charged on a per SIM/vessel basis per month for a minimum duration for at least 12 months, except for FBB.COM Plan, where the minimum duration will be one month.

4.3. Subscription and allowance for the first/last month/period will be pro-rated.

4.4. Should a SIM be suspended, then the subscription charge will continue to be applied.

4.5. When a user deactivates a subscription before the end of the minimum duration period, a charge relating to the outstanding subscription (i.e. the remaining portion of the minimum duration period at the monthly rate) will be made and this will be the lesser or the outstanding subscription for the remainder of the minimum duration period or the maximum terminations charges as follows:

Minimum duration of the contract	3 Months	12 Months	24 Months
Maximum Early Termination Fee	3 months subscription	3 months subscription	6 months subscription

4.5. On activation, the subscription and allowance for the first month will be pro-rated except for annual in advance plans where a full year subscription will be charged and a full associated allowance will be made available.

•The communication sessions in the "Data transmission over the Internet» (IP-traffic) are formed on the basis of the connections to the network. Such a formation is necessary for the implementation of the IP-traffic monitoring and cost calculation. Parameters of the formation of the communication sessions are as follows:

- The achievement of traffic volume - 2 MB;
- Duration of continuous connection – 12 hours;
- Disconnect of the communication session.

4.6. The duration of each communication session is rounded up in the following increments:

- «Telephone», «ISDN, Fax, Voice 3.1 kHz» - 15 seconds;
- «Streaming IP» - 5 seconds;
- «StandardIP» - 0,0195 Mb

4.7. Minimum paid traffic for each communication session:

- «Telephone», «ISDN, Fax, Voice 3.1 kHz» - 30 seconds;
- «Streaming IP» - 30 seconds;
- «Standard IP» - 0,0977 Mb.

4.8. The total cost of telecommunications services per each SIM-card is settled as the sum of the costs of each communication session, indicated in the CDR detail. The cost calculation of each communication session is made in accordance with the rules of mathematical rounding up to 2-decimal digits. The total cost of services (the invoice amount) for the billing period is defined as the sum of all final costs of communication services on each SIM-card.

4.9. Subscriptions will continue to be charged after the minimum duration period has expired; this means that a SIM which is on a particular Package Rate Plan will continue to be charged at that subscription rate until a service order is received to either deactivate the SIM or to move it onto another Package Rate Plan. No new minimum duration period will be applied once the original minimum duration period has finished.

4.10. VAT is not included.

4.11. Approval is required for all plans 20GB and above. These plans are only available for type approved FleetBroadband 250 and 500 User Terminals. Inmarsat will validate all terminals provisioned and utilised against these plans and will terminate any agreement that does not have a FleetBroadband 250 or 500 terminal associated with it. Application form must be completed in order to subscribe to these plans.

4.12. Inmarsat analysis will regularly be undertaken to ensure that where there are two SIMs provisioned against a single Package Rate Plan, that both of these SIMs are in the same location. Where the Inmarsat in its reasonable opinion concludes that there is abuse of dual SIM Package Rate Plan, then it may decide at its sole discretion to either terminate such Plan forthwith for that Subscriber, refuse to make such Plans available to that Subscriber in the future, retrospectively charge the Subscriber for all traffic that has been the subject of such abuse at the normal rate that would ordinarily have applied to such traffic using the regular Standard plan charges that would have applied to each individual SIM or such other action as it sees fit.

4.13. Subscription Suspension.

- The subscription suspension fee will be introduced since 1st of January 2017.



- There is an option to suspend the subscription (Subscription Suspension) for a number of the FleetBroadband rate plans. This functionality will apply to the rate plans as detailed in Tables below.

- Effective 01 January, 2017 the subscription suspension fee will be 317,80 usd.

Monthly suspension subscription option usage conditions are below:

1.1

- D) Monthly suspension subscription option can be activated starting at 1st date of the calendar month
- E) Maximum 90 days per year
- F) During the Minimum Duration period the 90 days suspension could be taken as follows:
 - one Subscription Suspension period of 90 days,
 - three periods of 30 days,

When a Subscription Suspension period occurs during the Minimum Duration, the period of the Subscription Suspension will not count towards the Minimum Duration period.

1.2. During a Subscription Suspension period

- Any allowances are removed during a Subscription Suspension period
- Any usage during a Subscription Suspension period will be charged at the appropriate out of bundle rates for that rate plan.
- During a Subscription Suspension period, it is not possible for a SIM to be upgraded, downgraded, suspended or deactivated

1.3 Dual SIM Plan

Subscription Suspension is applied at a per vessel level and therefore applies to both SIMs.

4.14. Voice Allowance Plans

In addition to the data allowance plans, data and voice allowance plans are available.

Annual options for Voice allowance plans are based on multiples of the options above.

The allowance minutes include calls to fixed line and cellular destinations only. For the avoidance of doubt on-net calls are not included within the allowance.

The minimum duration period of the voice allowance plan will be the same as the underlying data plan, e.g. 12 months for the 250MB plan. To access one of these plans, SIMs will need to be upgraded to the new plan and a new minimum duration period will commence. Data allowances will be unaffected.

5. Shore to ship calls rate.

Service	Unit	Tariff (USD)
Shore to ship call (Inmarsat FleetBroadband)		
Shore-Ship	minute	4,00

Notes:

All rates are in USD. VAT is not included.

The subscriber has to call +7(495)2360100 and enter the purchased PIN-code, then Inmarsat mobile number and the press #.



6. INMARSAT FLEETBROADBAND COVERAGE.



FleetBroadband coverage

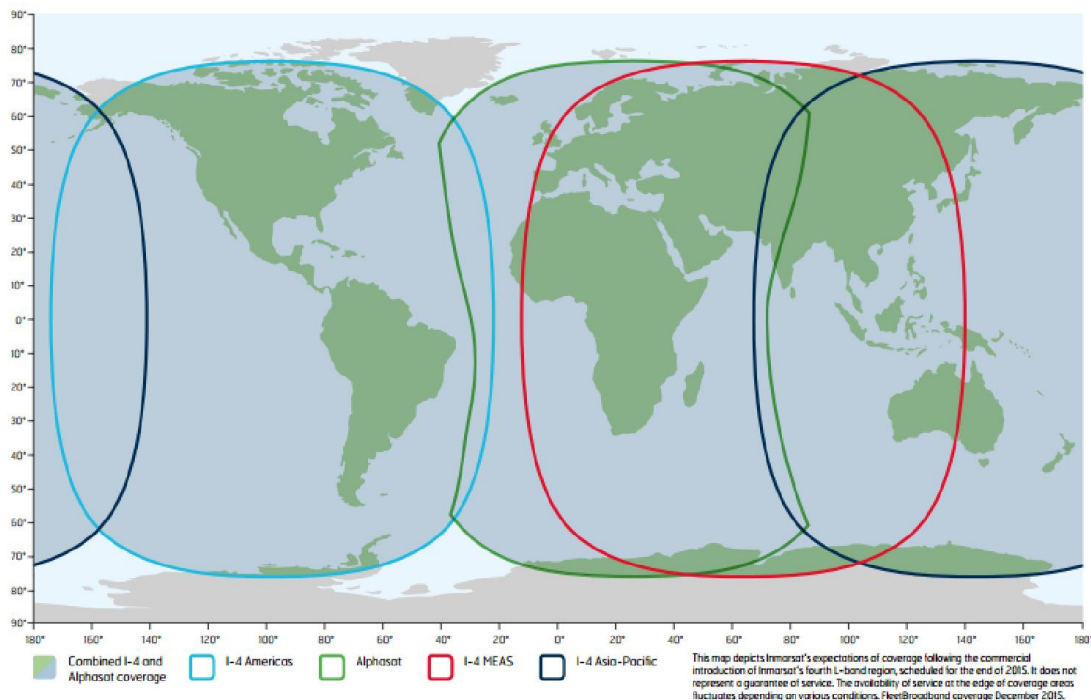

7. Value added services.

Maritime subscribers of Morsviazspudnik are provided with full range of value-added services available for Fleet broadband Inmarsat terminals:

- **FlyCarrier email software.** The service of e-mail address provisioning in the @marsatmail.com domain is free of charge to the customers using the Inmarsat terminals and having the contract with “Morsviazspudnik” for communication services. This service can be provided in two modes at the customer’s option:

- direct access to the marsatmail.com service using standard mail programs;
- access to the marsatmail.com mail service using the specialized FlyCarrier software.

The FlyCarrier application is aimed at optimizing the data transfer via IP satellite communication channels. The software system providing the data optimization and compression consists of the client and server parts. The client part (FlyCarrier application) is installed at the client’s PC, while the server part is installed at “Morsviazspudnik” marsatmail.com shore mail server.

The client part of FlyCarrier application receives messages from the standard mail program, compresses the data, sets up the connection with the shore server end of the system and transmits the data with the maximum possible IP traffic minimization. The FlyCarrier server part receives the messages, unpacks them and delivers to the mail (marsatmail.com), which ensures the delivery of the messages to the final addressee.

The client part of FlyCarrier application at the client’s PC takes the intermediate position (middleware) between the standard user mail program (for instance, Outlook Express) and the marsatmail.com mail server. FlyCarrier supports the joint work with basic mail programs (MS Outlook/Outlook Express, The Bat!, Mozilla Thunderbird, Eudora).

Main functions of FlyCarrier

- automatic compression of all messages sent to mail server / incoming messages from the mail server
- full-duplex operation mode (receipt and transmission are performed simultaneously)
- possibility of choosing the messages to receive from the mail server (algorithm is similar to IMAP 4) – you can prevent spam by confirming receipt from the known addresses only



- restoring receipt/transmission from the place of communication channel rapture while working with the mail server
- preliminary preparation of messages for receipt on the server part of FlyCarrier
- reduction in size of the original message up to 40% due to the optimized coding of the mail message (not taking into account its further compression)
- possibility of choosing the option of automatic change in image files resolution (maximal size of the image in pixels, color depth and image quality), which allows reducing the original size of the image 2-10 times without visual deterioration of the quality – optimal if the transmitted image is not intended for printing
- automatic recording of communication sessions
- possibility of visual observation of receipt/transmission process
- maintaining the statistics of received/transmitted messages of the users with automatic counting of the receipt/transmission cost
- possibility of using as mail server
- possibility of local mail accounts development on vessels – these users will have an opportunity to receive/transmit messages only between themselves and the basic account without the opportunity to work via satellite communication line
- possibility of independently developing accounts on vessels while operating in pre-paid mode – account is developed with a certain balance, the tariff is determined (\$/MB) and within this sum the user is able to receive/transmit messages via satellite communication channel
- possibility of developing accounts with traffic quotas –user is provided with the certain free volume of traffic, which can be used within the day/any other specified period. While exceeding this quota user's operation is blocked (this option is widely used by the companies practicing the selection of some volume of free traffic for crew-members to plan traffic flow and limit its usage)
- possibility of account development for automatic files exchange – many ship-owners have their own applications for fleet management, which presuppose constant files exchange with the vessel in order to provide consistent support and management. This option allows configuring FlyCarrier program so that all the messages with attachments received at the address of this account will be automatically received and recorded to certain folders/computers that form part of the vessel's local network. Similarly, the files of the preliminarily chosen folders/computers will be automatically taken and sent to the ship-owner at the specified mail address
- FlyCarrier, while working with the FleetBroadband terminals, is able to receive/transmit text messages (SMS) via FBB for different purposes, for instance, to receive a message if there are urgent messages or messages from the preliminary chosen addresses
- possibility of manual (by clicking the relevant button) and automatic (this option is switched off on default) connection and disconnection with the Internet. Thus, the terminal can be managed from the Fly Carrier program
- possibility of sending diagnostic report to the program's developers with short user's notes in case of program error
- data collection on location (this option is switched off on default). On default the data transmission is carried out 4 times a day. The information on location is put into the waiting line to be sent every 3 miles of the distance covered. The maximum volume of the transmitted data does not exceed 15 Kb per day. The data transmission is carried out during the same communication session of the mail receipt/transmission
- displaying the information on terminals location (+tracks) at Google maps
- (Google API) in Mosaik user web-portal.

To use the FlyCarrier application it is necessary to be a registered user of the marsatmail.com server (to get login and password from technical support helpdesk@marsat.ru) and ask the DVD with the program and instruction, or download them from the server www.flycarrier.com

• **Firewall** – The service is available on the network «Morsviazsputnik» (APN marsat.bgan.inmarsat.com and static IP address needed) and allows you to restrict access to web resources on the basis of predetermined rules of «white» or «black» list.



Restricted access (Firewall) can be used in conjunction with installed PC software products that protect the end user from unauthorized access to the Internet network or from the network (no automatic software updates).

Key possibilities:

- Firewall – Provision of firewall service with the possibility of traffic filtration by virtue of IDP system (Intrusion Detection & Prevention), WEB filtration executed on basis of web-sites division in terms of categories, security levels and user black and white lists. Filtration on applications and content.
- Possibility of IPSec VPN allocated channels arrangement providing communication with the user's equipment except for traffic exchange through public Internet.
- Possibility of HTTP traffic acceleration, automatic optimization of graphical data.
- Possibility of IP traffic monitoring (IP forensics).

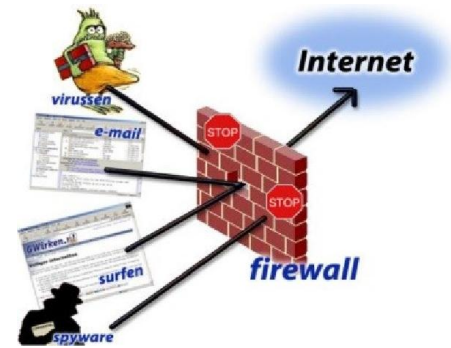

• **Voice shore to ship – VoIP – optimized voice over IP**

- Optimized service over the Inmarsat channels
- Suitable for FleetBroadband and BGAN terminals
- Voice via IP to both ways
- Pre-payment and post-payment
- Multiple channels

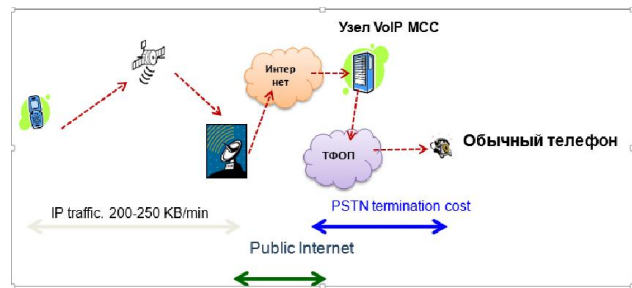

• **Web acceleration.**

• **Monitoring costs on communication services.** The tool allows you to track communication service charges (INMARSAT Broadband) in a real-time mode, receive e-mail notifications of credit limit achieved. Monitoring service allows you to monitor the balance of both a single device and a group of terminals.

• **IP forensics.**

• **Arrangement of internet-cafes for crew and passengers.**

“Morsviazspudnik” provides the technology for the unified communications, which offers phone communication (Crew Calling) operating simultaneously in various standards of the satellite communication – Inmarsat 3 and Inmarsat 4, as well as the access to the Internet for the vessels and aircrafts crews.

The access to the system is provided by a unified short access code - SAC (short access code) and a personal PIN code.

The system presupposes:

- Cards with the pre-paid traffic volume (crew calling)
- Various tariff plans for various groups of users
- Voice communication
- Calculations in minutes and seconds
- Standard duration of the PIN code – 30 minutes
- Payment for the connection time only
- Quanta calculation by 20 seconds
- Notification on the balance in English and Russian
- Balance replenishment
- Displaying the statistics on the calls made
- E-mail and Internet for crew-members

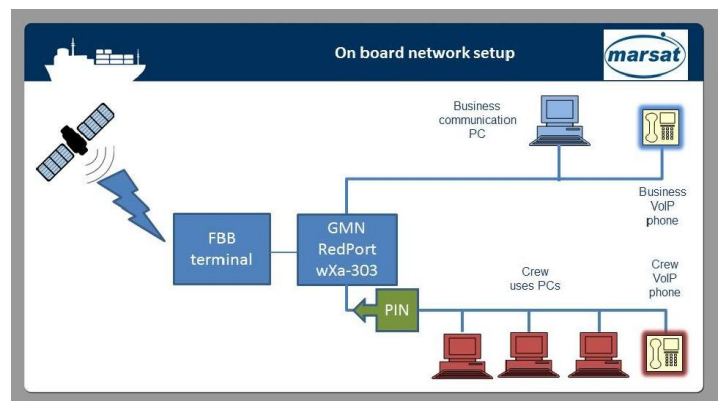



- The Marsatmail mail server and FlyCarrier program for traffic optimization
- Internet café based on CISCO or GMN box

We provide our partners and agents with the access to the management interface for the generation and blocking of PIN codes, balance replenishment and statistics generation.

The Inmarsat 4 terminals can operate by using the VoIP technology. In this case to transmit the voice one uses the standard transmission channel (background).

The access to the Internet is provided to the crew-members of the vessel on the pre-paid terms by entering the personal PIN code.

• *Mosaik User WEB-Portal*

Mosaik user web-portal offers a full range of administrative information, possibilities to optimize the costs and traffic monitoring, as well as inbuilt tools for managing BGAN, FleetBroadband, SwiftBroadband services and Inmarsat satellite phones.

Basic Functions of Mosaik User WEB-Portal:

- user's personal account
- possibility to activate and deactivate SIM-cards
- possibility of SIM-cards temporary suspension
- possibility to change the voice mail settings and adjust the firewall functions
- possibility to observe the 'hot' traffic for all SIM-cards
- invoices and calls details in electronic form (user can download invoice in the beginning of each month from the Mosaik portal or get it automatically via e-mail in PDF, D91 or CSV)
- traffic flow statistics
- setting the rules for using the Internet for SIM-cards

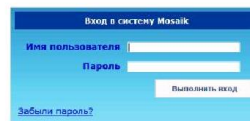

If you have any questions please contact helpdesk@marsat.ru.

www.marsat.ru
e-mail: sales@marsat.ru